

SURFACE FINISHES

3D PRINTING



PROTOLABS

- 4-5 **DIRECT METAL LASER SINTERING (DMLS)**
- 6-15 **STEREOLITHOGRAPHY (SLA)**
- 16-17 **CARBON DLS**
- 18-19 **MULTI JET FUSION (MJF)**
- 20-23 **SELECTIVE LASER SINTERING (SLS)**
- 24-25 **POLYJET**
- 26-27 **CUSTOM FINISHING**

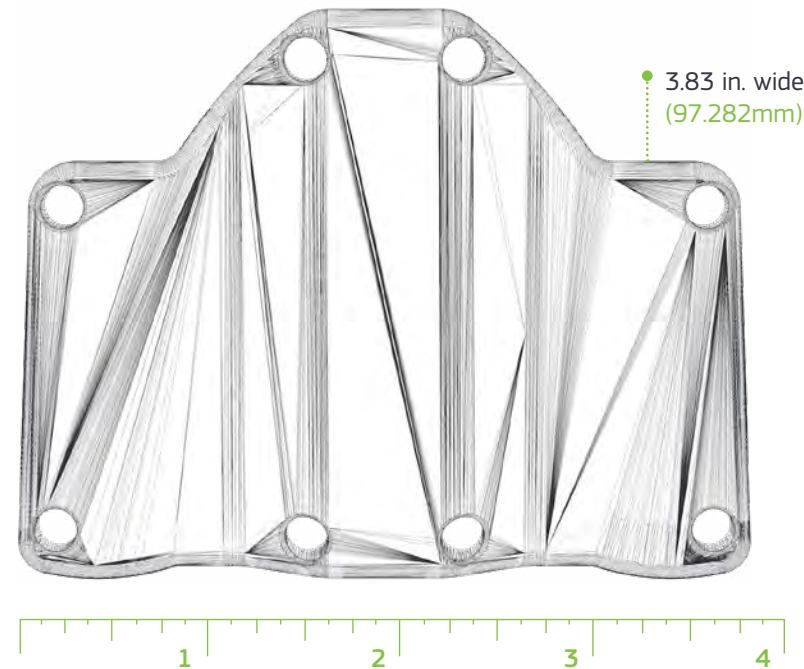
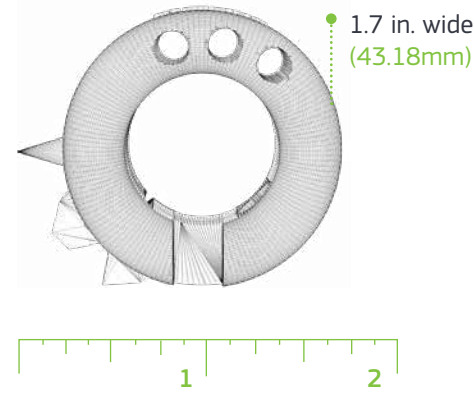

Welcome to our guide to 3D printing surface finishes. Depending on the additive manufacturing technology, build direction, resolution, and materials you choose, part aesthetics can be impacted. Use this guide to get a quick look at your finishing options and what you can expect when your 3D-printed parts arrive.

Note: This guide does not show all materials and finish levels. It is intended to be representative of the types of materials and finish levels offered.

PLASTIC	TECHNOLOGY	UNFINISHED	NATURAL	STANDARD	CUSTOM FINISH
ABS-Like Black (RenShape SL7820)	SLA	•	•	•	•
ABS-Like White (Accura Xtreme White 200)	SLA	•	•	•	•
ABS-Like Gray (Accura Xtreme Gray)	SLA	•	•	•	•
ABS-Like MicroFine™ (Gray and Green)	SLA	•	•	•	•
ABS-Like Translucent/Clear (WaterShed XC 11122)	SLA	•	•	•	•
PC-Like Translucent Advanced High-Temp (Accura 5530)	SLA	•	•	•	•
PC-Like Translucent (Accura 60)	SLA	•	•	•	•
Ceramic-Like White (Advanced High-Temp PerFORM)	SLA	•	•	•	•
PP-Like Translucent White (Somos 9120)	SLA	•	•	•	•
Rigid Polyurethane (Carbon RPU 70)	CARBON	•	•		
Flexible Polyurethane (Carbon FPU 50)	CARBON	•	•		
PA12 Black	MJF			•	•
PA12 White (PA650)	SLS			•	•
PA11 Black (PA850)	SLS			•	•
PA12 40% Glass-filled (PA614-GS)	SLS			•	•
PA12 Mineral-filled (PA620-MF)	SLS			•	•
TPU-70A	SLS			•	•
Digital Photopolymer (Clear/Translucent)	POLYJET			•	•*
Digital Photopolymer (Black)	POLYJET			•	•*
Digital Photopolymer (White)	POLYJET			•	•*
Digital Overmold	POLYJET			•	•*

* Custom finish on rigid durometer PolyJet parts only.

METAL	TECHNOLOGY	STANDARD	SEMI-BRIGHT	BRUSHED	CUSTOM POLISH
Aluminum	DMLS	•			•
Cobalt Chrome	DMLS	•			•
Inconel 718	DMLS	•			•
Stainless Steel 17-4 PH	DMLS	•			•
Stainless Steel 316L	DMLS	•			•
Titanium / Ti 6-4	DMLS	•			•
Metal Plating	SLA/SLS/MJF	•	•	•	•

MATERIAL SHOWN: 316 Stainless Steel

RESOLUTION: High (0.00079 in. layer thickness)



DMLS TEXT FEATURES

For best results, text should be inset at 0.015 in. (0.381mm) deep, 10-point font or larger, and bold if possible. Also consider the space between each digit—a minimum of 0.006 in. (0.152mm) gap for high resolution and 0.012 in. (0.305mm) for normal resolution is recommended.

CUSTOM POLISH

STANDARD



MATERIAL SHOWN: CuNi Plating over Ceramic-Like White (Advanced High-Temp PerFORM)

RESOLUTION: Normal (0.004 in. layer thickness)

FINISHING OPTIONS

Our standard metal-plating process for SLA/SLS/MJF coats the part with CuNi that gives parts the look, feel, and strength of metal, but without the weight. The combination of the material's strength, rigidity, and temperature resistance with CuNi plating takes strength, stiffness, and temperature resistance to a degree previously unattainable. Note: Custom polish, custom brushed, and custom semi-bright are finishing options for SLA metal-plated parts only.



6

CUSTOM POLISH

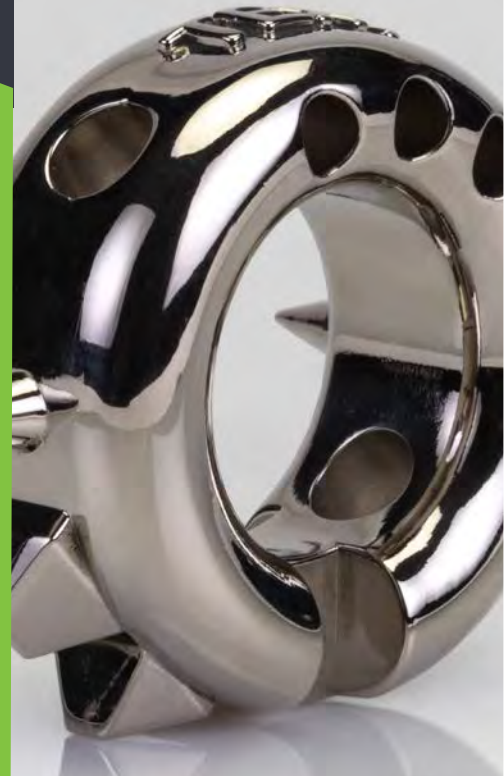

CUSTOM BRUSHED



CUSTOM SEMI-BRIGHT



CUSTOM STANDARD



MATERIAL SHOWN: ABS-Like Translucent/Clear (WaterShed)

RESOLUTION: Normal (0.004 in. layer thickness)

CUSTOM

Layer lines are removed and a clear coat is applied. All part surfaces will appear clear and glossy.

STANDARD

Parts with standard finish are grit blasted, and will appear matte or frosted in appearance.

NATURAL

With natural finishing, you get varying aesthetics based on build orientation. Parts are not grit blasted. All up-facing part surfaces will appear glossy.

UNFINISHED

With unfinished, you get varying aesthetics based on build orientation. Dots or standing nibs remain evident on the bottom of the part from the support structure remnants.

CUSTOM



STANDARD



NATURAL



UNFINISHED



MATERIAL SHOWN: PC-Like Advanced High-Temp (Accura 5530)

RESOLUTION: Normal (0.004 in. layer thickness)

THERMAL CURING

Boost heat deflection temperature by thermal curing parts. Once the PC-like advanced high-temp material is thermal cured, part appearance will transition from a light tan to darker amber. Note: Ceramic-Like White (Advanced High-Temp PerFORM) parts can also be thermal cured.

PRE-THERMAL CURE



POST-THERMAL CURE



MATERIAL SHOWN: ABS-Like Gray (Accura Xtreme Gray)

RESOLUTION: Normal (0.004 in layer thickness)

STANDARD

Supported surfaces are sanded, and the entire part is finely blasted for a consistent look. Note that layer lines are still present.

NATURAL

Supported surfaces are sanded down to eliminate the support nibs.

UNFINISHED

Dots, or standing nibs, remain evident on the bottom of the part from the support structure remnants.

MATERIAL SHOWN: ABS-Like Black (RenShape SL7820)

RESOLUTION: Normal (0.004 in. layer thickness)

DOWNFACING

Our standard process for ABS-like Black is to apply fixative to the downfacing side to restore surface finish resulting in a matte appearance.

UPFACING

Upfacing sides will have a glossy appearance.

STANDARD



NATURAL



UNFINISHED

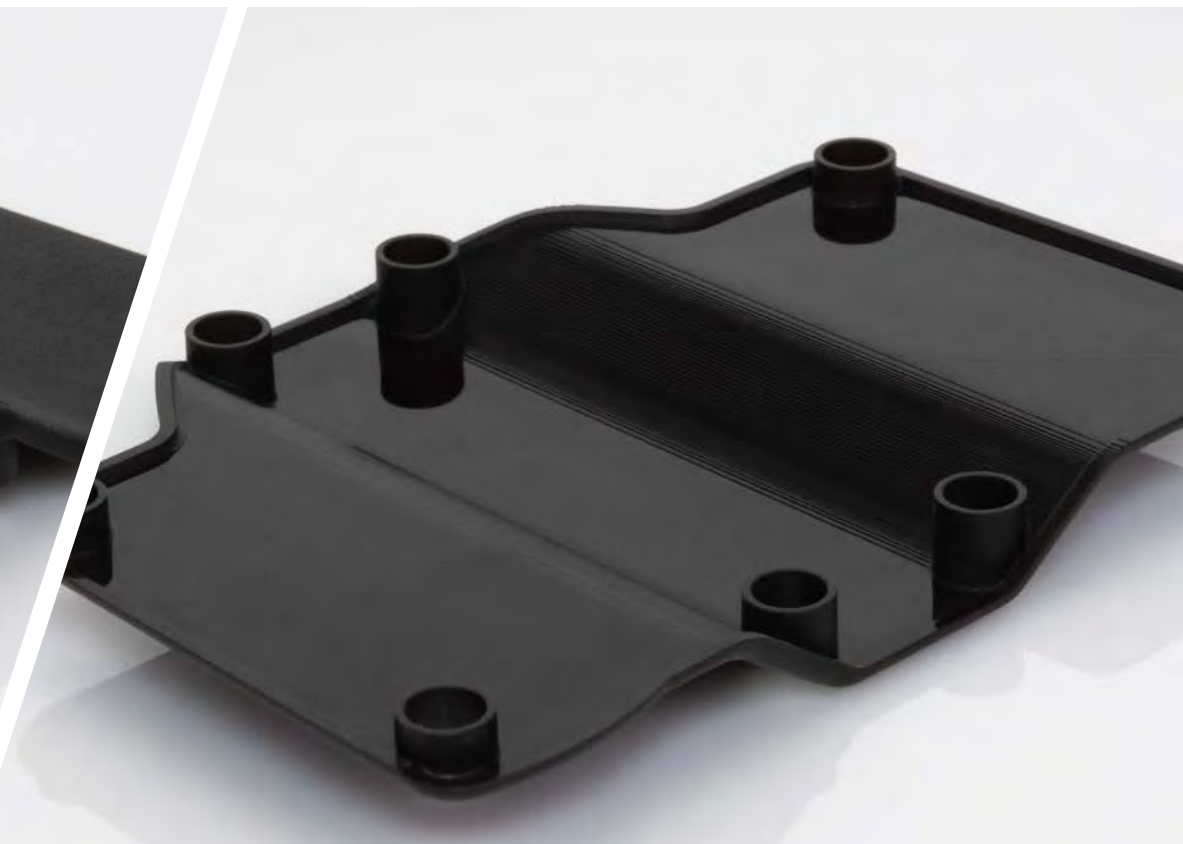

MATERIAL SHOWN: ABS-Like MicroFine™ Gray and Green

RESOLUTION: Micro (0.001 in. layer thickness)

CUSTOM

Layer line removal, paint with color matching, and clear coat application is available.

STANDARD

Supported surfaces are sanded, and the entire part is finely blasted for a consistent look. Note that layer lines are still present.

NATURAL

Supported surfaces are sanded down to eliminate the support nibs.

UNFINISHED

Dots, or standing nibs, remain evident on the bottom of the part from the support structure remnants.

14

CUSTOM



STANDARD



NATURAL



UNFINISHED



STANDARD



NATURAL



UNFINISHED



MATERIAL SHOWN: Rigid Polyurethane (Carbon RPU 70)

RESOLUTION: Normal (0.004 in. layer thickness)

UNFINISHED

With unfinished, you get varying aesthetics based on build orientation. Dots or standing nibs remain evident on the bottom of the part from the support structure remnants.

NATURAL

With natural finishing, you get varying aesthetics based on build orientation. Standing nibs are sanded flat.



MATERIAL SHOWN: PA 12 Black

RESOLUTION: Normal (0.00315 in. layer thickness)

Tapped and threaded inserts are available upon request.

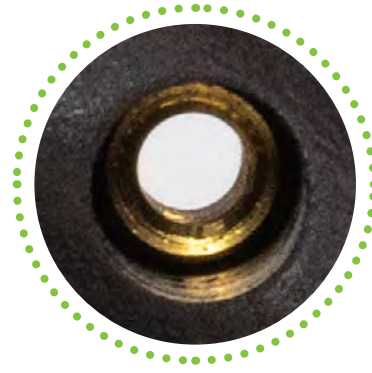

MATERIAL SHOWN: PA12 40% Glass-Filled (PA614-GS)

RESOLUTION: Normal (0.004 in. layer thickness)

FINISH: Standard



SELECTIVE LASER SINTERING

MATERIAL SHOWN: PA11 Black (PA 850)
RESOLUTION: Normal (0.004 in. layer thickness)
FINISH: Standard

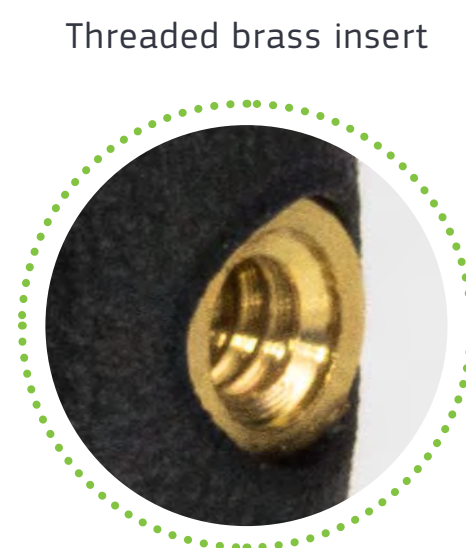
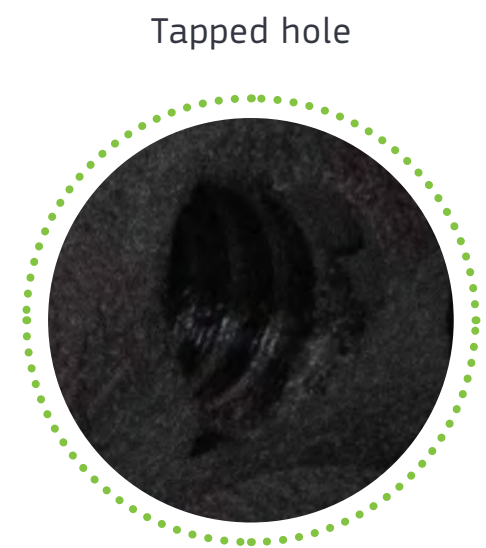
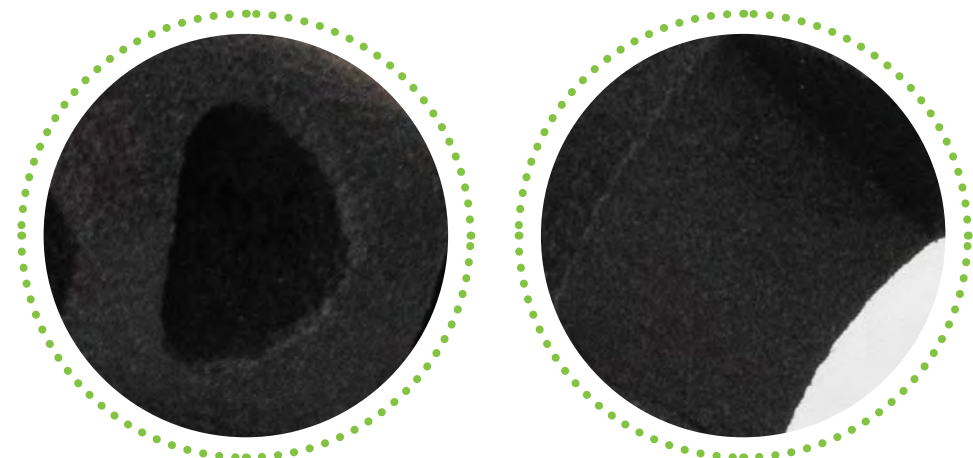

MATERIAL SHOWN: Digital Photopolymer (Clear Rigid)

RESOLUTION: Normal (0.00118 in. layer thickness)

FINISH: Standard

MATERIAL SHOWN: Digital Overmold

(Black 40 Shore A Durometer + Clear Rigid)

RESOLUTION: Normal (0.00118 in. layer thickness)

FINISH: Custom: clear coat applied to window

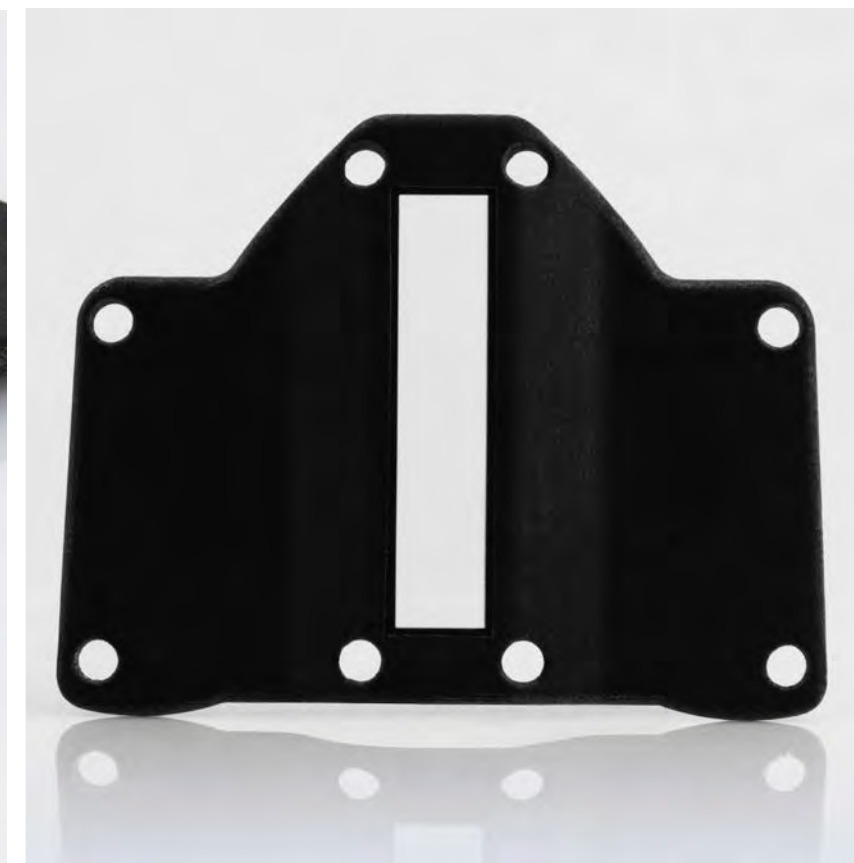
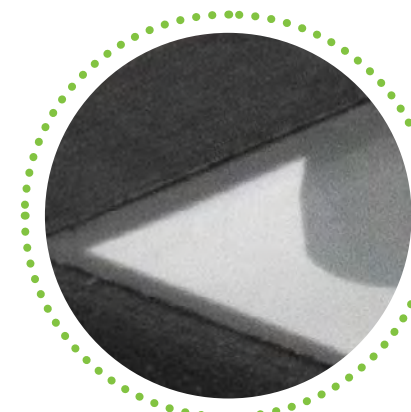

FINISHING OPTIONS

- Soft-touch paint
- Clear part finishing
- Painting
- Masking
- Color matching
- Decals and graphics
- Texturing
- Pantone matching

Custom finishing options are possible for most plastic 3D printing processes. Surface prep is needed in order to eliminate appearance of layer lines through paint.

MATERIAL SHOWN: ABS-Like Translucent/Clear (WaterShed)

RESOLUTION: Normal (0.004 in. layer thickness)

FINISH: Custom blue paint with texture added

MATERIAL SHOWN: PA12 White (PA650)

RESOLUTION: Normal (0.004 in. layer thickness)

FINISH: Standard finish with red dye



**CHINA METAL PARTS,
CORP.**

Manufacturing. Accelerated.®



CONTACT US

+86-755-27311095

inquiry.us@made-parts.com

us.mfgmachined.com

7th Industrial Zone, Shangnan, Shajing, Baoan,
Shenzhen, China.

Zip Code: 518125

ISO 9001:2015 Certified | ITAR Registered | AS 9100D Certified
©China Metal Parts, Corp. 1999-2019

3D Printing
CNC Machining
Sheet Metal Fabrication
Injection Molding